

HSK-1 User Manual

eem
LIFT CONTROLLER and RESCUE SYSTEM



“Beyond Usual Conditions”



EEM İTH. İHR. PAZ. ve TİC. AŞ.
ASANSÖR KUMANDA VE OTOMASYON SİSTEMLERİ



HSK-1

EMERGENCY RESCUE SYSTEM

USER MANUAL



Serial Number:.....

Version: 2.3

Dear Valued Client,

Thank you for purchasing the HSK-1 Emergency Rescue System developed using advanced power electronics technology. Our mission is to present our product in the best possible performance and satisfactory operation. In this respect, it was designed in our modern establishment and tested utilizing modern quality control methods. We highly recommend reading this document before installing, as it contains important information from operation to detailed troubleshooting tips and solutions.

 **WARNING** 

- This manual was designed to provide helpful operation and maintenance tips for personnel who are knowledgeable and educated on electric circuits of lifts.
- Deciding upon the excellence of the personnel installing and operating the system is under the responsibility of installer firm.
- Manufacturer is not responsible or liable for any damages that result from the misuse of, or the inability to use of the product.
- For safety, alterations and modifications are not allowed on the product.
- Personnel installing the HSK-1 Emergency Rescue System are themselves responsible from any damages they may harm.
- Complying with the legal regulations and safety rules are mandatory to avoid any harm to install and service personnel and product.
- This user manual being a part of the product should be kept near the installation for ready reference.

 **WARNING** 

- In this manual, **the connections establishment of safety circuits, their operations, the possible problems, troubleshooting tips and solutions** are explained.



WARNING



This lift has HSK-1 Emergency Rescue System.

In case of a power failure or blackout, HSK-1 Emergency Rescue System automatically activates and lowers or elevates the lift to floor level to provide for the safe exiting of the passengers.

Warning for technical personnel undertaking the maintenance of the lift:

- For your own safety, disconnect the HSK-1 Emergency Rescue System during the maintenance of the lift. For this reason, turn off the power at the fuses of battery and charge automation.
- HSK-1 Emergency Rescue System has an advanced battery charger. However, for a longer battery life, **we recommend operating the system several times during each maintenance work.** This is important to keep the system continuously operable.

OPERATING INSTRUCTIONS of HSK-1 EMERGENCY RESCUE SYSTEM

- HSK-1 Emergency Rescue System operates full automatic. It waits on standby mode when electricity is present.
- When the electricity outage occurs, HSK-1 emergency rescue system automatically starts operating and a warning message is displayed. Cabin starts to move to the nearest upper or lower floor, halts at the floor level and the door is opened. Thus, the rescue process ends.
- After the rescue process, it waits for electricity to be restored. Afterwards, the lift automatically starts to operate in normal operating mode.
- If HSK-1 emergency rescue system can not automatically start operating and implement rescue process, this may be caused by either a malfunction in the system or an external connection error. After the restoration of electricity, the lift can service from its own control panel.

NOTE: If desired, a copy of this page can be hung inside the lift cabin or somewhere the apartment administrator can reach.

STEP BY STEP OPERATION of HSK-1 EMERGENCY RESCUE SYSTEM

It facilitates troubleshooting of a connection failure to have knowledge of the overall process between the power outage and starting of HSK-1 and disconnecting it after moving the lift to the floor level. The following events occur when the power outage occurs.

1. When the electric power is lost (the absence of one phase is sensed as a power loss, as well), “P2.3- Cut in Time” starts to count down. If the building has a generator and it starts to supply energy, the rescue system does not start. In generator back-up systems, this time is adjusted to an appropriate value. After the time expires, RP relay of the HSK-1 is energized and rescue process starts. At that moment, if even the energy is restored, rescue process still continues and control panel does not energize.

2. Safety circuit transfer relays located on the HSK-1 is energized. In this moment, safety circuit and JF sensitive halter magnetic is connected to the HSK-1. If the lift is at the floor level, process jumps to step 8, else to step 3.

3. If rescue circuit is not turned on (open circuit, e.g. because stop button is turned off), an error message is displayed and rescue process ends. Process jumps to step 9. If safety circuit is turned on, RM motor relay is energized and process continues from step 4.

4. Motor is energized. In case of a connection failure in motor (e.g. motor connections are mistakenly connected to slow winding) “E8. Motor Error” is displayed and process jumps to step 9. If HSK-1 senses that motor connection is normal, brake is pulled and process continues from step 5.

5. After the brake is pulled, motor should start rotating immediately. In that case, process jumps to step 6. If motor does not rotate, the power is cut off to motor and brake is released. Afterwards, the motor is tried to be operated in reverse direction. If this is the second try of HSK-1 to rotate the motor, program jumps to step 4. If it is the third try, “e6. Can not rotate” error is displayed and program jumps to step 9.

6. The lift travels for a duration of “P2.5-Max Travel Time”. In this period, if the lift is not able to reach at the floor level “E7. Rescue Timeout” error is displayed and program jumps to step 9. If it reaches the floor level in this period, process continues from step 7.

7. Following the sensing of JF magnetics, the movement continues for a duration of “P2.6-Travel Time After JF”. During the rescue process, lift motor rotates with a 1/10 of nominal rotating speed. Therefore, if the lift is halted just after JF magnetics is sensed, the cabin may not have reached at the floor level yet. In this case, “P2.6-Travel Time After JF” may need to be adjusted. At the end of this period, the lift is halted, RM relay is de-energized and process continues from step 8.

8.RK, door relay is energized. The lift door is energized and opened in a time period of adjusted “P2.7-Door Opening Time” parameter.

9.Until the energy is present again, RP relay located on HSK-1 stays energized. That means, RP contactor located on the Rescue control panel can not be pulled in. This feature allows the system to operate as a phase safety relay as well. When the electric power is present, system waits a time period of “P2.4 Cut Out Time” and at the end of this time RP relay located on HSK-1 is de-energized. Thus, RP contactor located on the Rescue control panel is pulled in and main control panel is energized.

HSK-1 THE USE OF MENUS IN EMERGENCY RESCUE SYSTEM

In HSK-1 emergency rescue system, all settings are grouped under a “menu tree” and all parameters are numbered. In this way, reaching a parameter, displaying and adjusting its value is extremely easy. Four buttons exist in HSK-1, namely ENTER, ESC, UP, DOWN. Pressing ENTER button for 3 seconds in stand-by mode of HSK-1 allows you to enter the menu. Holding ENTER button down for a long time in any part of the menu allows you to save all changes you’ve made and then the menu is exited. In the similar way, holding ESC button down for a long time lets you canceling all changes you’ve made and menu is exited. The menu tree is illustrated in Figure 2.

EXPLANATION OF THE PARAMETERS:

1- General Settings:

1.1- RESCUE NUMBER: The number of rescues that have been undertaken successfully since the HSK-1 Emergency Rescue System started to operate is indicated. Change is not allowed.

1.2- CLOCK SETTING: HSK-1 has a real time clock. This parameter sets the system clock.

1.3- DATE SETTING: This parameter sets the date. Date program has been designed taking into account the leap year.

1.4- LANGUAGE - DIL: HSK-1 screen can display the messages in Turkish, English or German languages. This parameter sets the language. (Please contact EEM Engineering if you would like any other language to be included)

1.5- MANUFACTURER: The name, phone number and web address of EEM Engineering is displayed.

1.6- PRODUCTION DATE –VERSION NO: Production date and version no of HSK-1 is displayed.

1.7- SERIAL NUMBER: Serial number of the product is displayed. You may be asked to declare this number when you consult EEM Engineering for technical support.

2- Service Settings:

2.1- MOTOR FREQUENCY: This is the drive frequency of the lift motor during the rescue process. If this value is not adjusted to an appropriate value for the motor, it can not start or may operate noisily. Factory set value is 6 Hz, which is appropriate for a widely used 8.2ps motor. This value must be **reduced for increased motor power and increased for reduced motor power.**

2.2- REVERSE ROTATION LIMIT: HSK-1 Emergency Rescue System can predict whether the motor is rotating or not by sensing the motor current. If it does not rotate, the motor current is higher than its nominal current value. This parameter must be adjusted between the nominal current value of the motor and the stall current value of the motor, i.e. the current it draws when it does not rotate. This value can be easily determined using a trial and error method.

In Figure 1-a and Figure 1-b, the motor currents drawn from HSK-1 Emergency Rescue System in case of motor's stalling and rotating conditions respectively are graphically illustrated. Reverse rotation limit must be adjusted to such a value that, the motor must draw more current than the limit value when it is unable to rotate. In the same manner, when it rotates, it must draw less current than the limit value. If reverse rotation limit value is chosen in the 1st region, even if the motor is unable to rotate, the system falsely decides that it rotates. If the limit is chosen in 3rd region, even if the motor rotates, the system falsely decides that it is unable to rotate. For that matter, the correct limit value is present in the 2nd region.

Practical setting method:

- If motor is unable to rotate, “Rescuing” is displayed, and some time later “Can not reach at the floor level” error message is displayed, decrease the reverse rotation limit.
- If motor rotates in one direction, stalls and rotates in the reverse direction, once again stalls and rotates in other direction, and “Can not rotate” message is displayed, increase the reverse rotation limit.

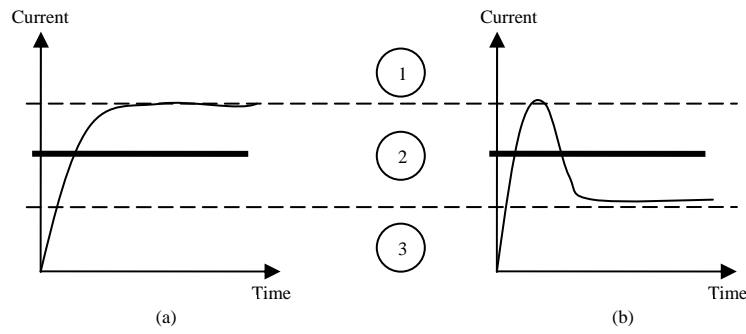

Figure 1.

2.3- CUT IN TIME: It indicates the required time for HSK-1 to start rescue process after the energy is cut-off. If the normal power is restored before this time expires, HSK-1 does not start. If the normal power is restored after the starting of HSK-1 rescue process, it does not stop until the process completes.

2.4- CUT OUT TIME: At the moment the power went off, if the lift is at the floor level or the rescue process is not yet complete or for any reason the rescue process have not been able to end, HSK-1 Emergency Rescue System outputs a message and waits in stand-by mode. At that moment, after the power is restored, the amount of time before disconnecting HSK-1 and transferring lift control to main control panel is specified by this parameter. If power goes off again before this time expires, it waits for the normal power to restore.

2.5- MAXIMUM TRAVEL TIME: It indicates maximum allowed rescue time. This duration must be long enough for the lift to reach the nearest floor level. For safety reasons however, assigning it a very large value is not appropriate. It must be adjusted as regards to the longest distance between two floors in the building.

2.6- TRAVEL TIME AFTER JF: Because the motor rotates slower than its nominal speed during the rescue process, at the moment JF magnetic is sensed and the lift is instantly stopped, on some occasions the lift may not be able to reach at the floor level. In order to prevent this, a setting has been added namely travel time after JF. By the help of this setting, the lift can be stopped exactly at the floor level. It is possible to adjust this value with a sensitivity of 100ms.

2.7- DOOR OPENING TIME: The door opens when the lift is at the floor level. This parameter determines the amount of time to open the door.

2.8- JF CONTACT AT FLOOR: This parameter sets the JF contact to be in closed or open state at the floor level. Generally JF contact is set to be in open state at the floor level. However, in some lift systems it may be used in closed state at the floor level.

2.9- COOLER STOPPING TEMP: The temperature of the fan mounted upon the HSK-1 Emergency Rescue System is constantly measured. If the temperature increases above a pre-determined value, fan automatically starts to operate. This parameter sets the temperature limit for stopping the fan.

2.10- DOOR MOTOR FREQUENCY: This parameter sets nominal operating frequency of the door motor.

3- Rescue System Test:

It is a very useful feature used particularly in troubleshooting during cutting in the rescue system and in the case of a failure.

3.1- R-S-T TEST: It is used to control correct sensing of the presence of 3-phase 380V supply voltage by HSK-1.

3.2- JF TEST: It is used to test JF sensitive halter magnetic.

3.3- SAFETY TEST: It is used to test safety circuit connection. Any connection failure in the safety circuit is displayed in the screen.

3.4- BRAKE TEST: It is used to test brake connection. The brake is released as long as “UP” button is pressed.

3.5- MOTOR TEST: It is used to test inverter and motor connections. As long as “UP” button is pressed motor rotates in one direction and as long as “DOWN” button is pressed motor rotates in the other direction.

3.6- DOOR TEST: It is used to test inverter and door connections. As long as “UP” button is pressed, the door opens.

99- Exit:

99.1- SAVE: All changes implemented are saved and menu is exited.

99.2- CANCEL: All changes implemented are cancelled and menu is exited.

99.3- RETURN TO FACTORY DEFAULT: Factory settings are restored and menu is exited.

NOTE: HSK-1 Emergency Rescue System can keep error records with date and clock information. In order to ensure a correct date and clock information, after cutting in of HSK-1, connect the jumper located in CON8 connector between the left most two pins. Therefore the batteries will be connected in and even in case of power loss, date and clock information will not be lost.

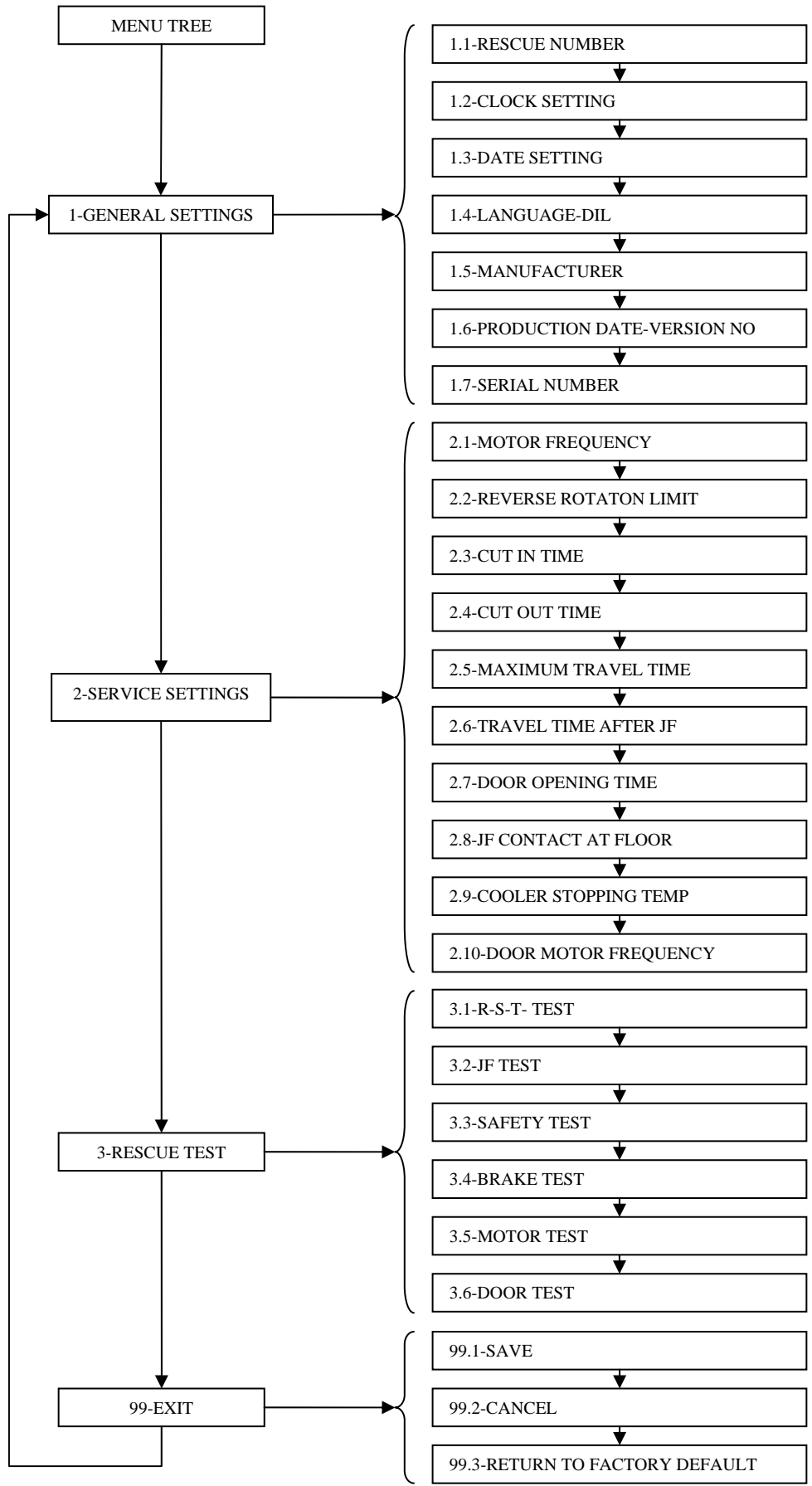

Figure 2

FAULT CODES

HSK-1 Emergency Rescue System detects a great deal of faults and by displaying them on the screen it helps users troubleshooting the failure easily. The fault codes displayed on the screen is as following.

E1. CHARGE FUSE ERROR: It indicates that the glass fuse of battery charger located on HSK-1 Emergency Rescue System is blown. The case of a disconnection between 55VAC charge voltage and rescue system (i.e. because charge w-automaton fuse located in rescue control panel is in OFF state or 55VAC terminal is not connected) is considered as the same condition. The condition of blown charge fuse does not hinder rescue process. It means that, if electric power is lost when the charge fuse is blown, the rescue system tries to move the lift to the floor level. However, as the charging can not be carried out, system will not be able to operate when the batteries ran out of their energies. Use a 3A glass fuse to replace the charge fuse.

E2. BRAKE FUSE ERROR: It indicates that break fuse located on HSK-1 is blown. In this condition, rescue process can not be implemented. Use a 5A glass fuse to replace the break fuse.

E3. MOTOR FUSE ERROR: It indicates that motor fuse located on HSK-1 is blown. In this condition, rescue process can not be implemented. Use a 15A glass fuse to replace the motor fuse.

E4. DRIVER ERROR: It indicates a fault in inverter stage. In this condition, rescue process can not be implemented.

E5. LOW BATTERY: If the battery voltage decreases below 45V, HSK-1 shows this fault and rescue process is cancelled. If battery voltage is high enough in stand-by mode, but it decreases below 45V during the motor start-up or during operating, one or more batteries in the battery bank may be faulty. The faulty battery can be detected by the measurement of battery voltage. In the rescue system test menu, the motor test menu is entered and while testing the motor each of the battery voltages are measured. Batteries with a terminal voltage below 10,5V must be replaced.

E6. CAN NOT ROTATE: HSK-1 attempts three times to rescue the lift. If it can not succeed in all these attempts an error output is given and rescue process ends.

E7. RESCUE TIMEOUT: If it can not reach at the floor level in the maximum travel duration, it outputs this fault and the process ends.

E8. MOTOR ERROR: While it implements rescuing process, the safety is the first consideration of HSK-1. In the beginning of rescuing process, a voltage is applied to motor. If motor draws more current than a determined value break is released and rescuing process starts. However, if motor does not draw any current the brake is not released and “H8. Motor is not

present” error message is displayed and rescue process ends. The source of this error may be RM motor relay or a motor connection fault. If HSK-1 displays this fault code, please check RM relay and motor connections. HSK-1 has to be connected to motor’s fast windings.

E9. OVER TEMPERATURE: HSK-1 continuously controls the temperature of fan. If the temperature excessively increases (reaches 75 °C), HSK-1 protects itself. When the temperature reaches 65 °C, it becomes active again.

FREQUENCY ASKED QUESTIONS (FAQ):

- *What can I do to prevent resetting of the clock?*

Connect CON8 connector, which is located in the lower side of the keypad, to the left most side. Thus, microcontroller will be able to be supplied by batteries.

- *Why is RP relay located on HSK-1 stays constantly energized?*

Three-phase 380V supply voltage is sensed by HSK-1 and in case of any failure in mains grid, it prevents operation of main control panel. This feature allows HSK-1 to operate as a phase safety relay.

- *Although charge fuse is not blown, why is “Charge fuse is blown” error displayed?*

This fault code is displayed in case of either 3A glass fuse of charge circuit is blown or 55VAC charge voltage is not present in CON1 connector. Please check the connections of CON1 connector and 3A w-automaton charge fuse.

- *“Rescuing” is displayed in the screen but motor does not rotate. Some time later “H7.Can not reach to floor level” is displayed. What should I do?*

Increase the maximum travel time.

- *“Rescuing” is displayed in the screen but motor does not rotate. Some time later “H7.Can not reach to floor level” is displayed. What should I do?*

First of all, check the motor connections. Motor terminals of HSK-1 must be connected to fast winding of motor. The motor may not be able to start due to any loose connection. Afterwards, it must be checked whether the motor rotates in terms of the adjusted motor drive frequency. For this purpose, enter “3.5-Motor Test” program under the “3-System Test” menu. Consequently press up and down buttons and make sure that motor rotates. If the motor can not rotate in both directions, please decrease motor drive frequency from “2.1 Motor Frequency” menu. If it can rotate now, decrease the value a little in “2.2 Reverse Rotation Limit” menu.

- *While the motor is rotating, it stops and tries to rotate in reverse direction. Then “H6. Can not rotate” fault is displayed. What should I do?*

Increase the value in “P2.2 Reverse Rotation Limit” menu.

- *I do not want to use RP contactor, which stays constantly energized. If I disconnect the main phase, feeding main control panel, can I still safely operate HSK-1?*

Yes. You will not have to use constantly energized RP contactor by disconnecting the phase of supply transformer in main control panel. Relays located on HSK-1 have contacts with 250V/5A, and RP1, RP2 terminals are normally closed sealed contacts. Supply phase of main control panel can be connected through this contact. However, we recommend that a relay is energized through normally closed sealed contacts of RP1, RP2 terminals and connect normally closed sealed contacts of this relay through supply phase of main control panel.

- *In initialization, the first line of LCD is darkened and nothing is displayed. What should I do?*

Turn off the power. Unplug the jumper (connector 8 – CON8) of the battery. After waiting approximately 1 minute turn on the power of HSK-1 and connect the jumper two left most pins.

- *“H4.Drive fault” is constantly displayed. What should I do?*

Get technical assistance from EEM Engineering.

- *Fault code is displayed without energizing of any relays. What should I do?*

Replace R102 coded resistance (2R2 2W).

- *Brake fuse was blown. I replaced the brake fuse but brake fuse blown again. What should I do?*

Be sure connections of brake is correct.

- *Sometimes motor/brake/charge fuse is falsely informed to be blown. What should I do?*

Check the fuse-holders. Make sure that the fuses are tightly screwed in their fuse-holders.

- *Motor and/or brake fuse is constantly blown. What should I do?*

Get technical assistance from EEM Engineering.

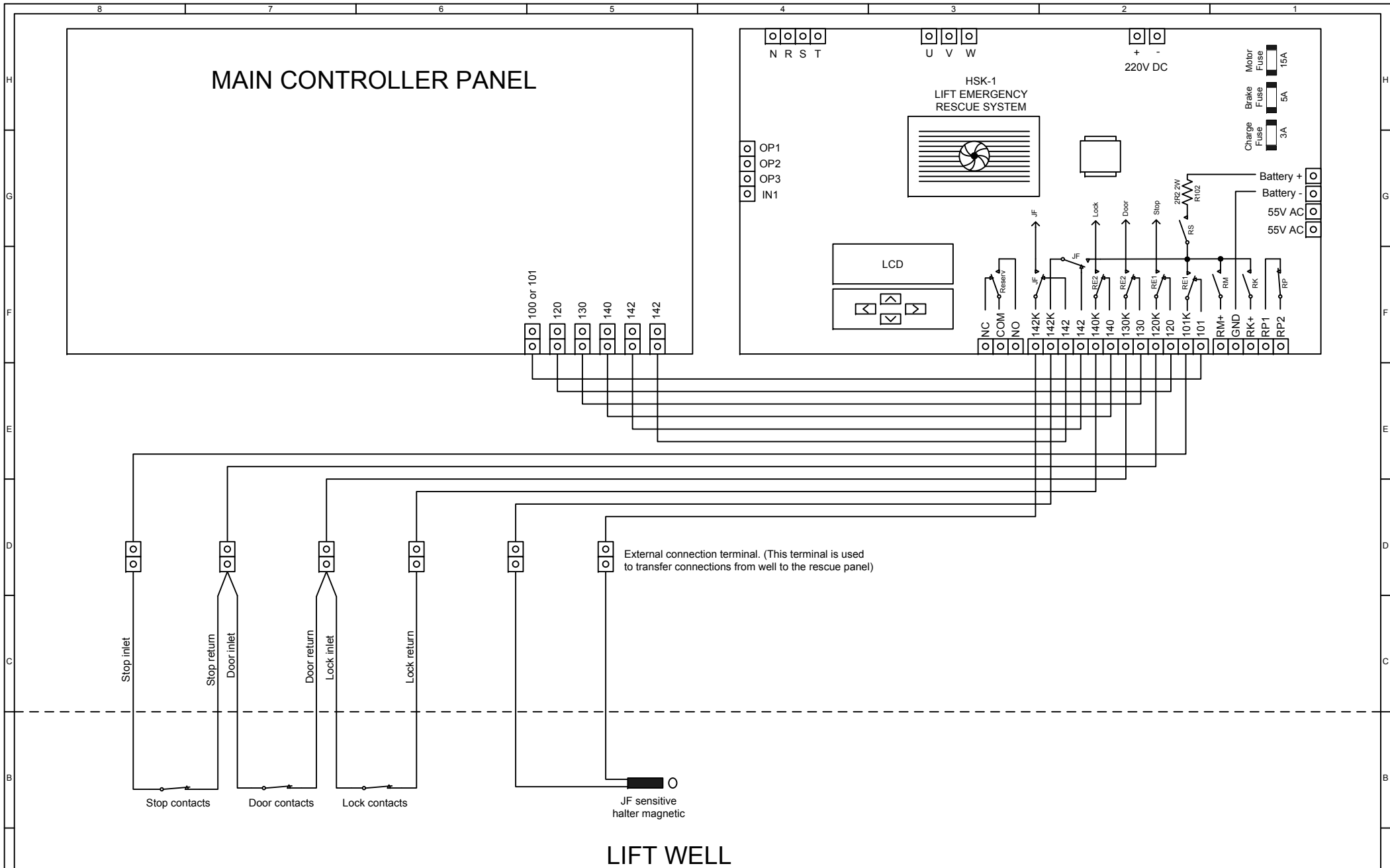

LIFT WELL

| | | | | | | | | | |
|---------------------------------------------------------------------------------------------------------------------------------------------------------------------------------------------------------------------------------------|----------------------------------------------------------------|--|--|--|--|--|------------------|---------------|---------|
|  <p>EEM Import Export Co. Lift Control Systems</p> <p>Tel : +90.332. 342 41 27 - 342 41 28 Fax : +90.332. 342 41 29 www.eem.com.tr</p> | Project name HSK-1 Emergency Rescue System with External Panel | | | | | | Drawn by ZD - BA | | |
| | Drawing name Safety Circuit Connection Diagram | | | | | | Controlled by SH | | |
| | Description | | | | | | Version 3.0 | Date 03.04.06 | Page 14 |
| | | | | | | | | | |

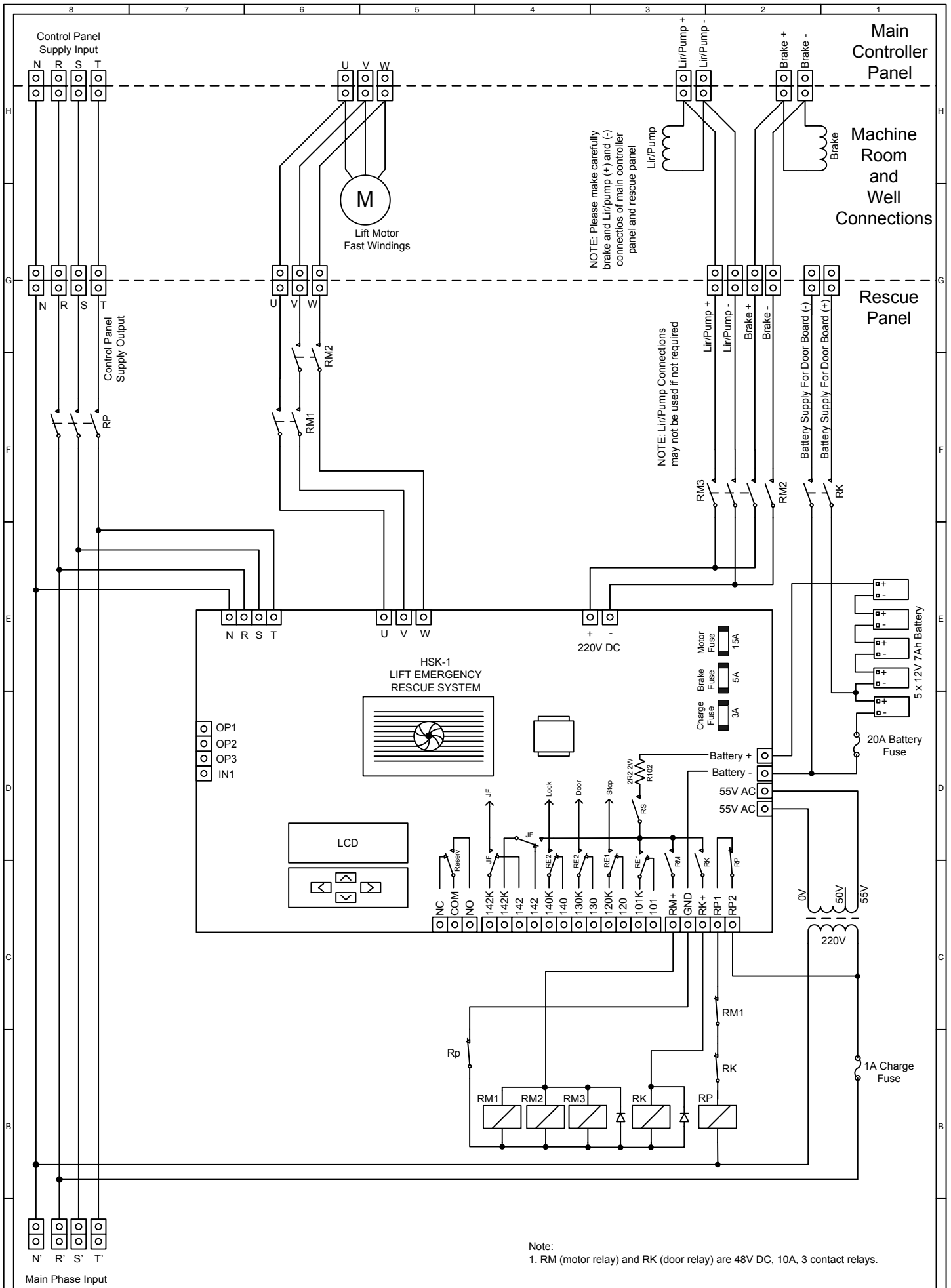

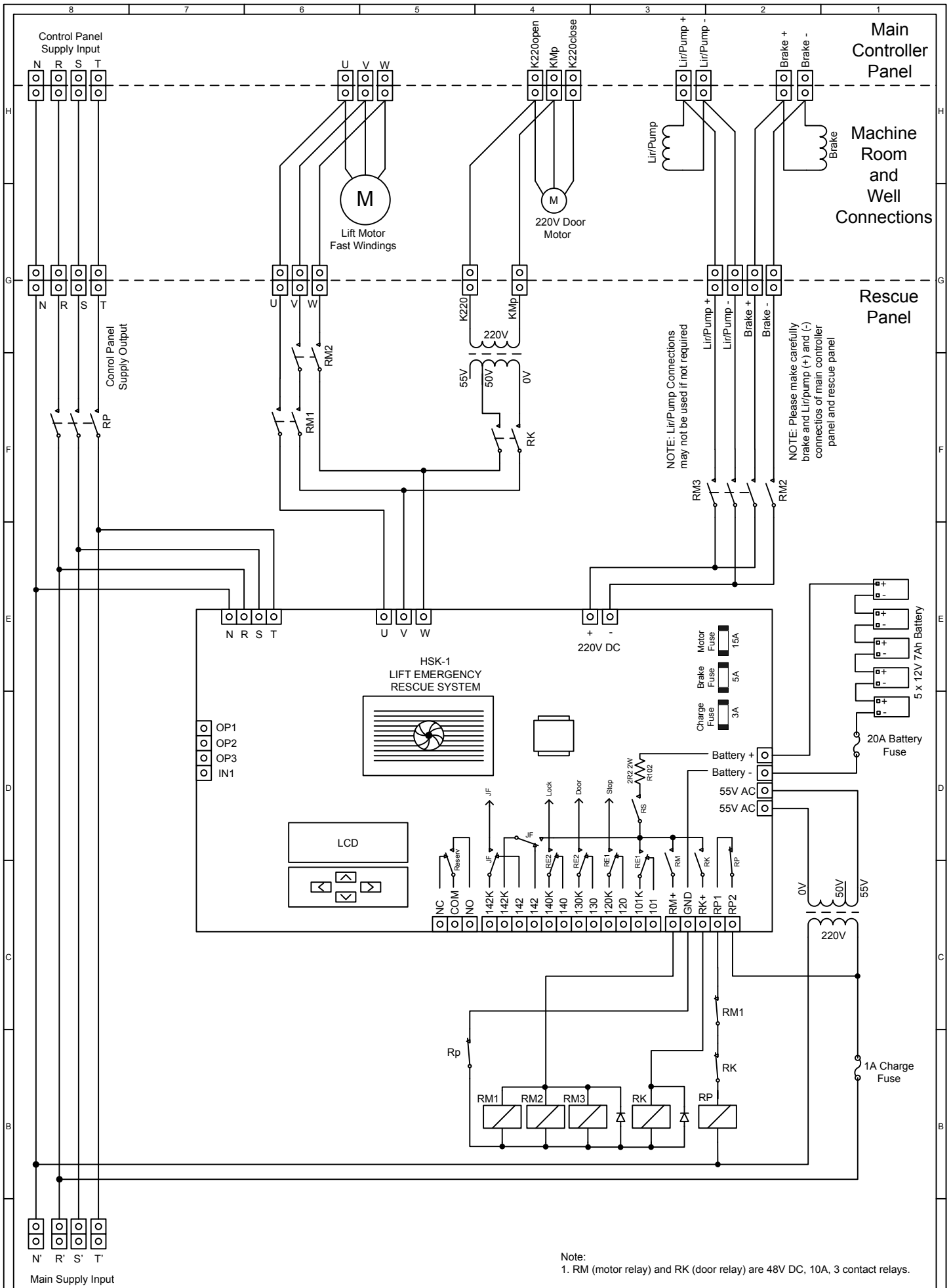

Note:
1. RM (motor relay) and RK (door relay) are 48V DC, 10A, 3 contact relays.

| | | | | | |
|--------------------------------------------------------------------------------------------------------------------------------------------|--------------|---------------------------------------------------|---------------|----------|------|
| EEM Import Export Co. Lift Control Systems Tel : +90.332. 342 41 27 - 342 41 28 Fax : +90.332. 342 41 29 www.eem.com.tr | Project name | HSK-1 Emergency Rescue System with External Panel | Drawn by | ZD - BA | |
| | Drawing name | HSK-1 Application with 220V Door | Controlled by | SH | |
| | Description | | | Version | 3.0 |
| | | | Date | 03.04.06 | Page |

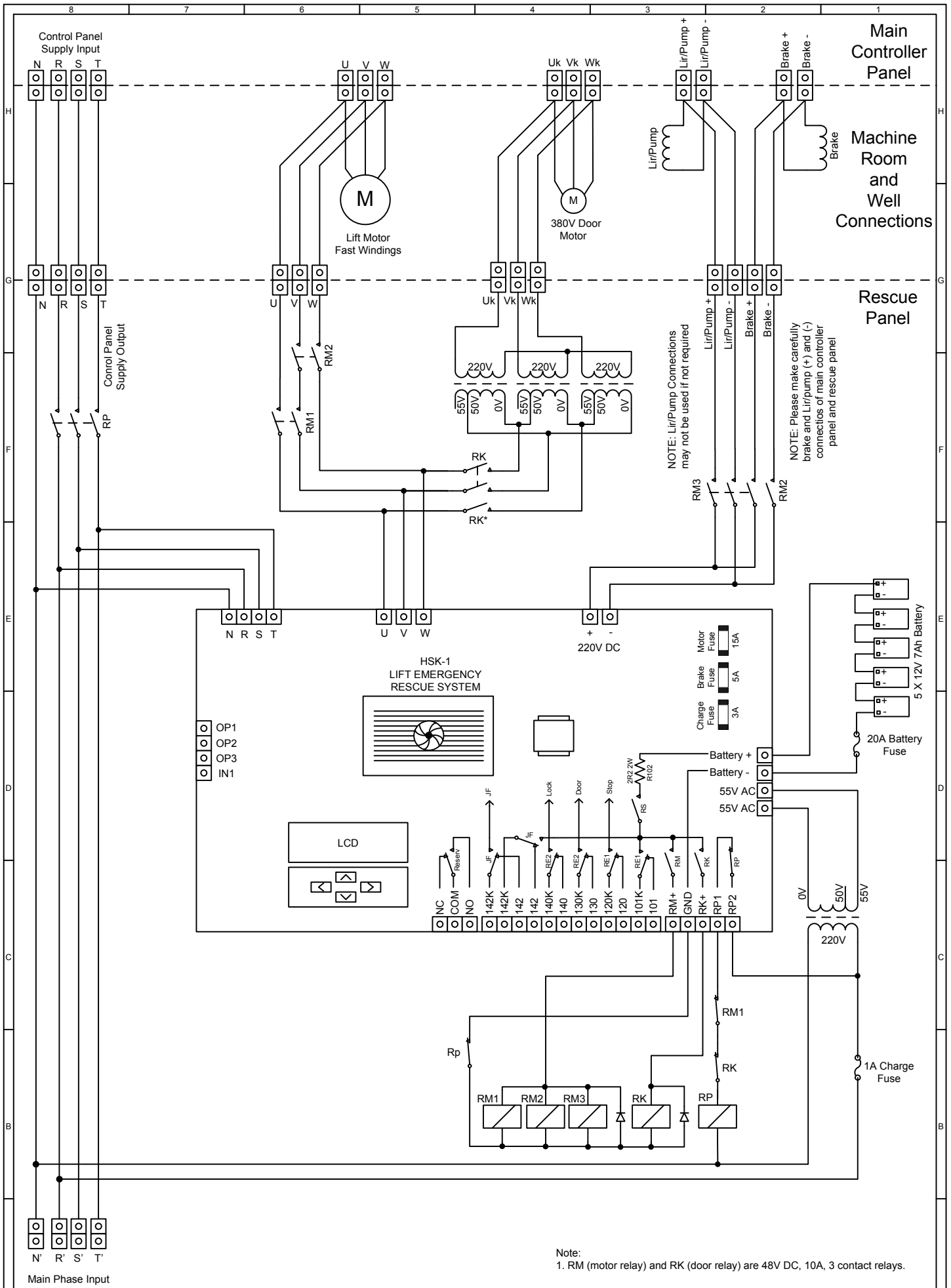

NOTE: Lir/Pump Connections may not be used if not required

NOTE: Please make carefully brake and Lir/pump (+) and (-) connects of main controller panel and rescue panel

Note:
1. RM (motor relay) and RK (door relay) are 48V DC, 10A, 3 contact relays.

| | | | | |
|--------------------------------------------------------------------------------------------------------------------------------------------|--------------|---------------------------------------------------|---------------|---------------|
| EEM Import Export Co. Lift Control Systems Tel : +90.332. 342 41 27 - 342 41 28 Fax : +90.332. 342 41 29 www.eem.com.tr | Project name | HSK-1 Emergency Rescue System with External Panel | Drawn by | ZD - BA |
| | Drawing name | HSK-1 Application with 380V 3 Phase Door Motor | Controlled by | SH |
| | Description | Version 3.0 | | Date 03.04.06 |
| | | | | Page |

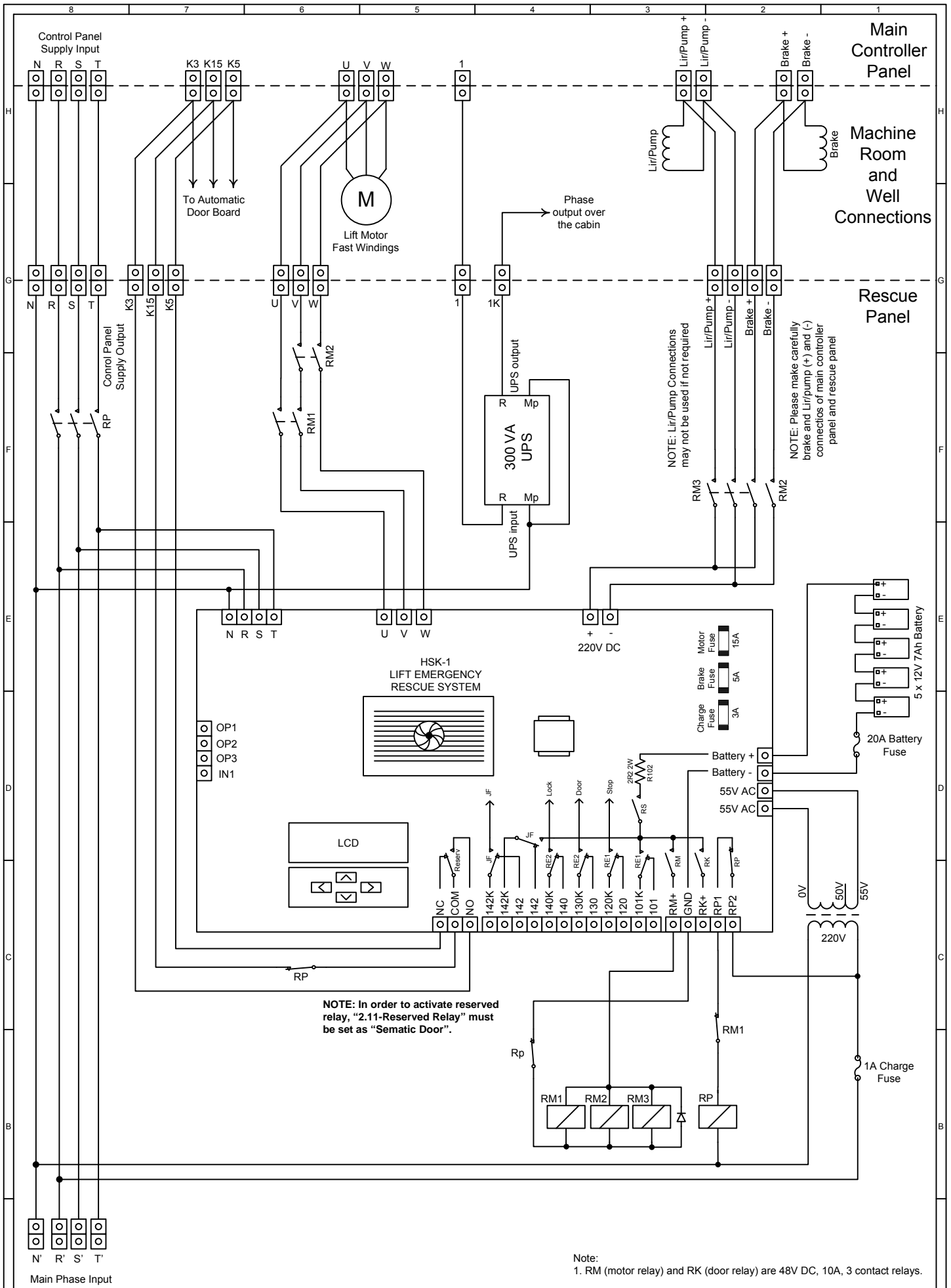

NOTE: In order to activate reserved relay, "2.11-Reserved Relay" must be set as "Sematic Door".

Note:
1. RM (motor relay) and RK (door relay) are 48V DC, 10A, 3 contact relays.

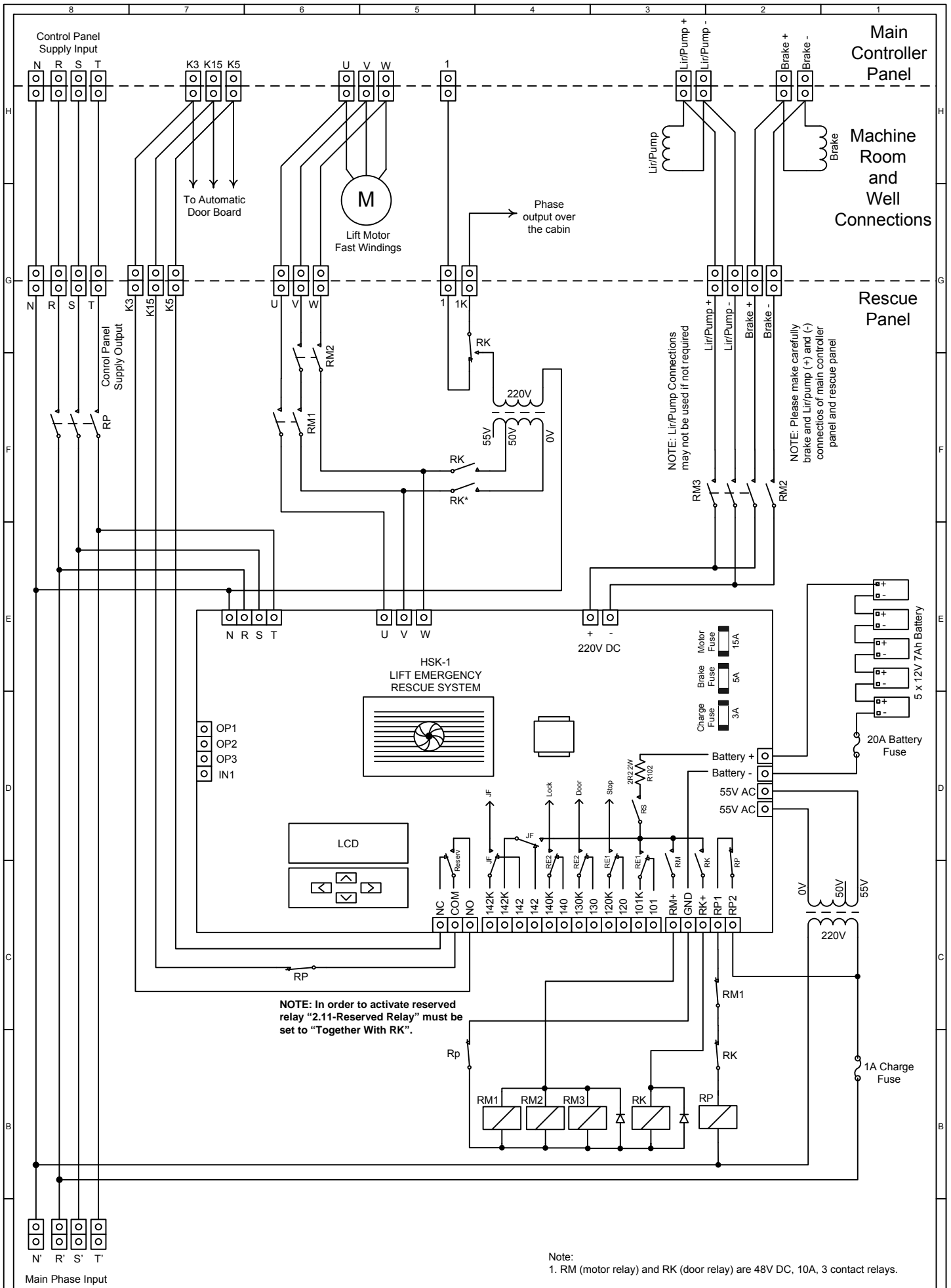

NOTLAR:

1. HSK-1 üzerindeki RP rölesi üzerinden pano trafosunun fazı kestirilmelidir. (RP rölesi 220V/5A'e dayanıklı kontaklara sahiptir.)
2. HSK-1 üzerindeki "K" rumuzlu kodlar "Kuyu" 'yu ifade etmektedir.
3. Şema dikkatlice takip edilirse aşağıdaki sonuçlar ortaya çıkar.
 - a. Normal çalışma anında (101-101K), (120,120K), (130-130K), (140-140K), (142,142K), (142,142K) uçları HSK-1 üzerinde bulunan transfer rölelerinin normalde kapalı kuru kontakları üzerinden kısa devre olmaktadır.
 - b. Kurtarma anında transfer röleleri konum değiştirmekte, tüm emniyet devresini ve JF şalterlerini HSK-1 kendisi beslemektedir. Buradan da anlaşılacağı gibi HSK-1 Acil Kurtarma Sistemi, tüm sistemlere uyarlanabilen, pano bağımsız bir üründür.

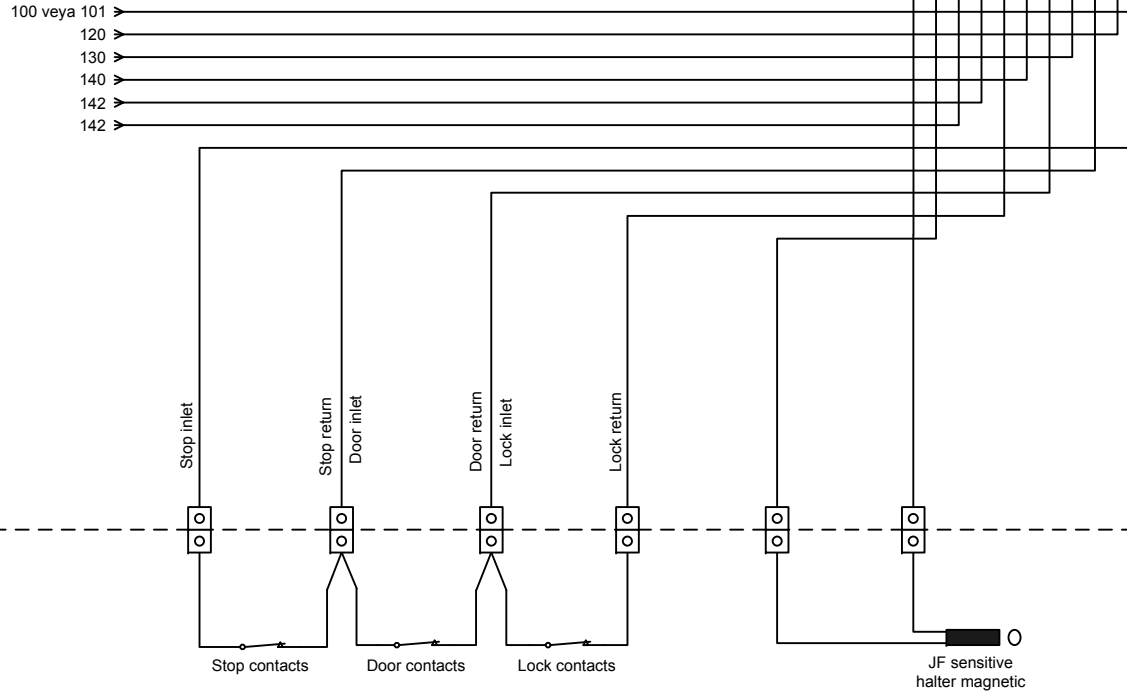

LIFT WELL



EEM Import Export Co.
Lift Control Systems

Tel : +90.332. 342 41 27 - 342 41 28
Fax : +90.332. 342 41 29

www.eem.com.tr

Project Name HSK-1 Emergency Rescue System with Internal Panel

Drawing Name Safety Circuit Connection Diagram

Description

Drawn by ZD - BA

Controlled by SH

Version 3.0

Date 03.04.06

Page 20

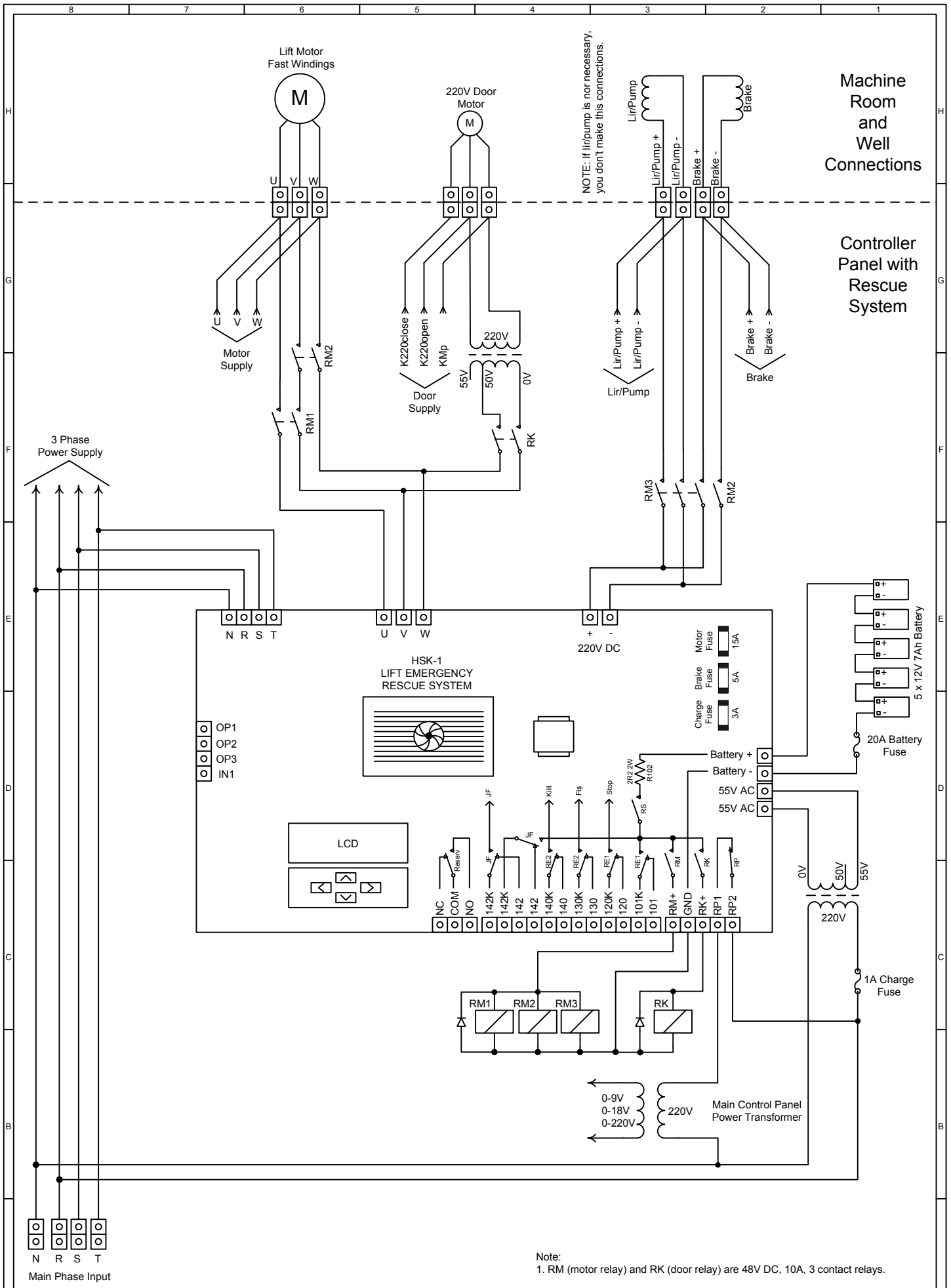

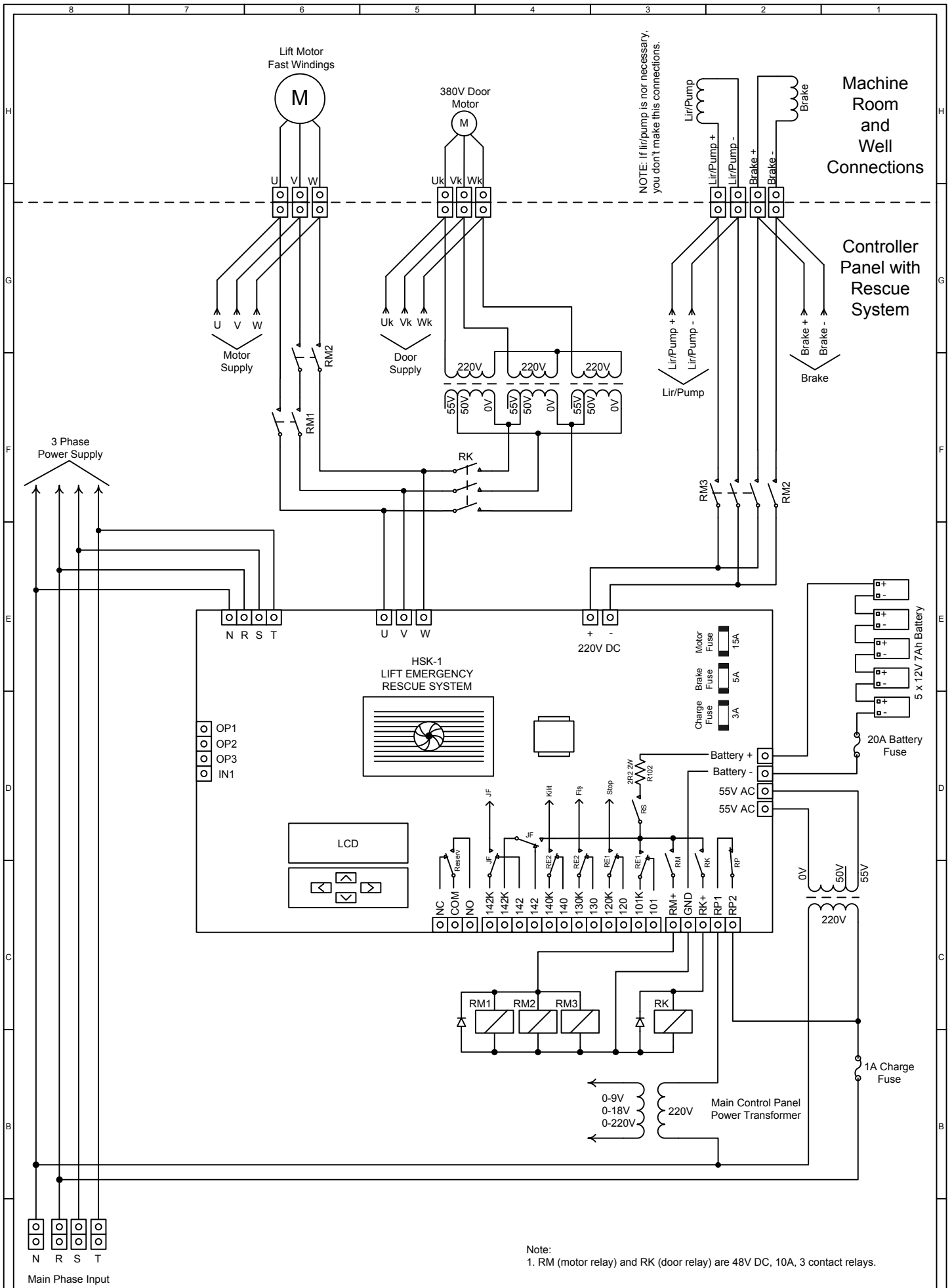

Note:
1. RM (motor relay) and RK (door relay) are 48V DC, 10A, 3 contact relays.

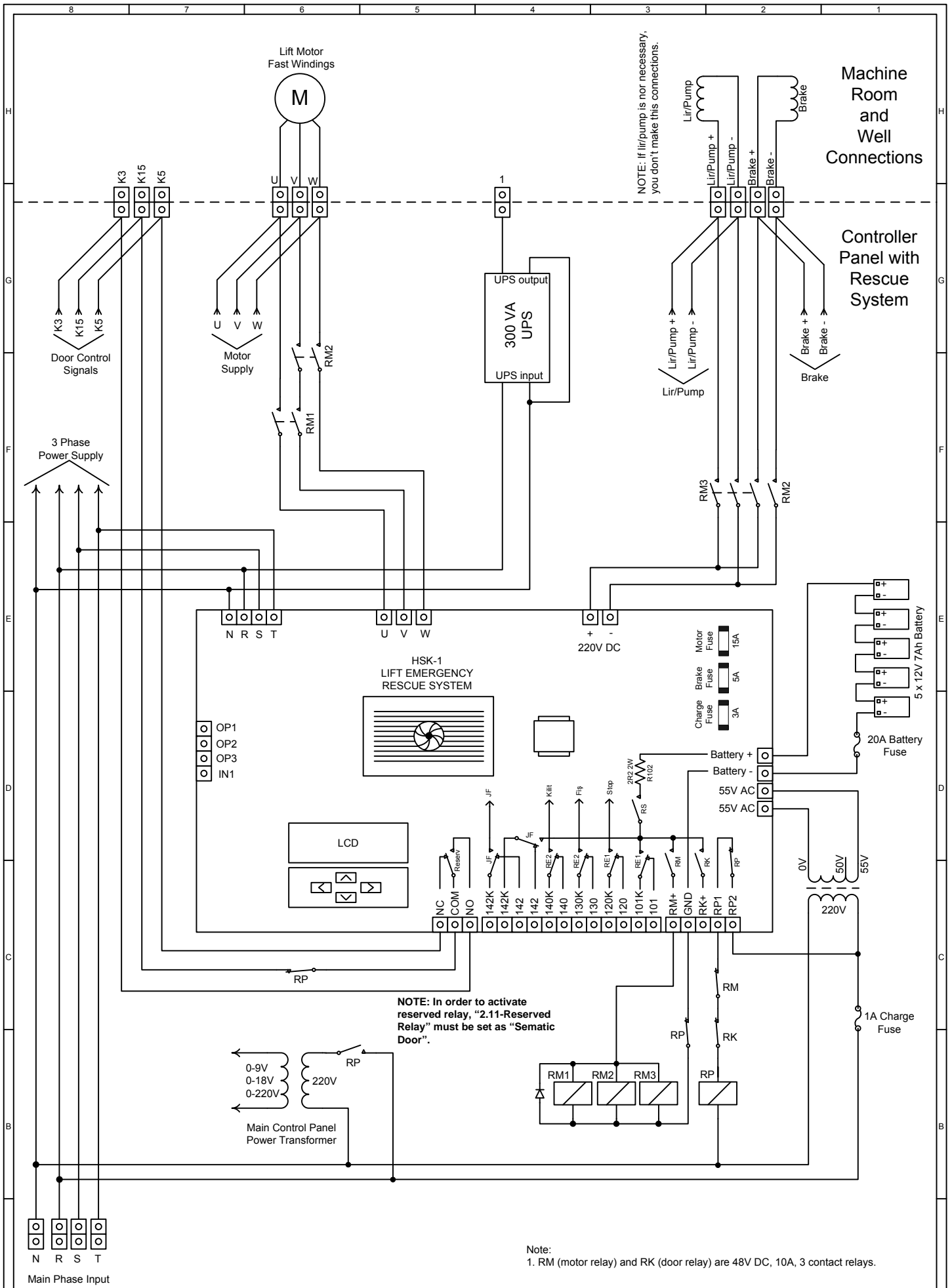

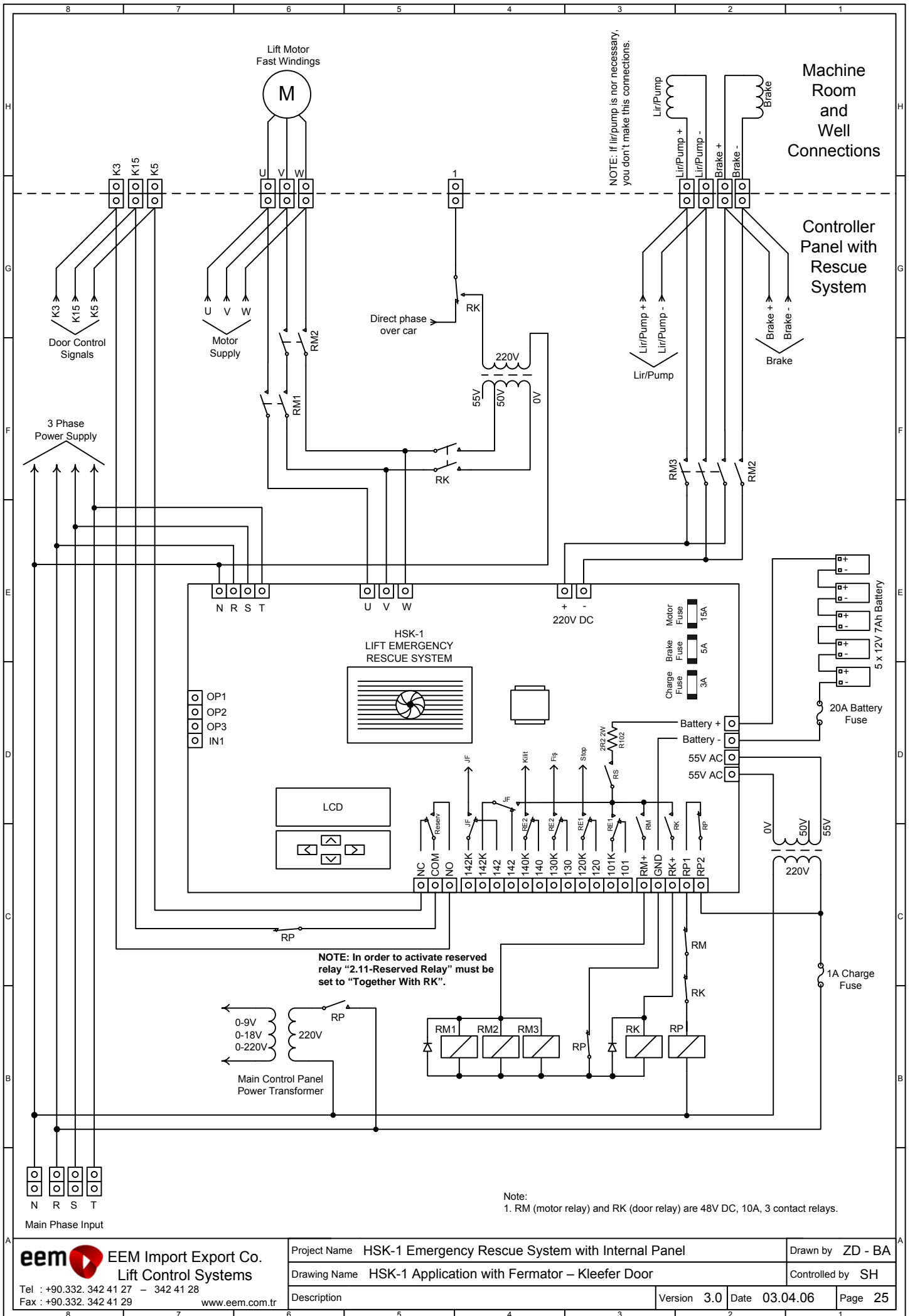

NOTE: If lift/pump is not necessary, you don't make this connections.

Machine Room and Well Connections

Controller Panel with Rescue System

AB UYGUNLUK BEYANI EC- DECLARATION of CONFORMITY

İMALATÇI / MANUFACTURER :

EEM İTH. İHR. PAZ.ve TİC. A.Ş.

TİP / TYPE :

HSK-1

İMALATÇI ADRESİ / MANUFACTURER ADDRESS :

Fevzi Çakmak Mah. Yaş Meyve ve Sebzeçiler Sit.
10515. Sok. No:24 Karatay / Konya / Türkiye

ÜRETİM YILI / YEAR OF MANUFACTURE :

Etiket Üzerinde / See data label on product

ÜRÜNÜN ADI / PRODUCT NAME :

Acil Kurtarma Ünitesi / Emergency Rescue Unit

SERİ NO / SERIAL NUMBER :

Etiket Üzerinde / See data label on product

UYGULANAN STANDARTLAR / THE FOLLOWING STANDARDS :

EN 81-1, EN 81-2, EN 55011+A1:1999, EN55011+A2:2002,
EN 61000-3-2+A2:2005, EN 61000-3-3+A1:2001, EN 61000-6-2, EN 61000-6-4

UYGULANAN DİREKTİFLER / THE FOLLOWING DIRECTIVES :

Asansör Direktifi 95/16/AT / Lift Directive 95/16/EC
LVD Direktifi 73/23/AT / LVD Directive 73/23/EC
EMC Direktifi 89/336/AT / EMC Directive 89/336/EC

Üzerinde seri numarası yer alan ürün için, kullanıcıya
teslim edilen kullanım kılavuzundaki şartlara
uyulması durumunda yukarıda belirtilen standartlara
ve direktiflere uygunluğunu beyan ederiz.

We declare eligibility of above mentioned standards
and directives to comply with the represented
conditions on the user manual for the serial number
on the product.

TEST LABORATUARI / TEST LABORATORY

Esım Test Hizmetleri San. Ve Tic. A.Ş.
İmes Sanayi Sit. C Blok 308. Sok. No:46
81260 Y.Dudullu / İstanbul / Türkiye

EMC TEST BELGE NO / EMC TEST CERTIFICATE NUMBER : EMC EEM-524/ESİM

FİRMA SORUMLUSU / RESPONCE OF COMPANY : Yön.Kur.Bşk. Aşır AKDEMİR

YER-TARİH / PLACE-DATE : KONYA / TÜRKİYE / 03.07.2007

YETKİLİ İMZA / LEGALLY BINDING SIGNATURE :

eem
LIFT CONTROLLER and RESCUE SYSTEM



EEM İTH. İHR. PAZ. ve TİC. AŞ.

Tel: +90 332 342 41 27 - 28

Fax: +90 332 342 41 29

Fevzi Çakmak Mah.
Yaş Meyve ve Sebzeciler Sit.
10515. Sok. No:24
Karatay / Konya / Türkiye

www.eem.com.tr
bilgi@eem.com.tr